



# LITHIUM

## Lithium-ion battery range











GS Yuasa are the only major manufacturer to produce Valve Regulated Lead Acid, lithium-ion storage and lithium-ion automotive starter batteries.

With our HQ in Japan, we have specialist production and operation facilities across the globe.

Our European sales, support and manufacturing companies allow us to facilitate successful projects on a local level.

### Lithium-ion manufacturing sites



/ GS Yuasa  
Kyoto, Japan



/ GS Yuasa  
Miskolc, Hungary



/ GS Yuasa  
Ebbw Vale, UK



/ Lithium Energy Japan  
Shiga, Japan



/ Blue Energy  
Kyoto, Japan



# Leading the way in lithium

For over 30 years, GS Yuasa lithium-ion batteries have delivered unparalleled performance in critical applications.

Using proven Japanese engineering and technology, our state-of-the-art cells and modules have been used in thousands of projects where failure is not an option.

GS Yuasa are the preferred choice for NASA, Boeing, Mitsubishi, Honda and countless energy storage solutions large and small. Our batteries are trusted to provide dependable energy storage in extreme operations from the depths of the ocean to outer space.

This unrivalled expertise, experience and technological know-how can be found in all GS Yuasa products.



**Lithium-ion starter batteries**  
Used by top vehicle manufacturers in their high performance vehicles.



**e-Oshima**  
Japan's first fully battery-powered, zero-emission passenger ship.



**Boeing 787 Dreamliner**  
Used for auxiliary power onboard Boeing's state-of-the-art airliner.



**H-IIIB Rocket No.5**  
Auxiliary systems within the H-II rocket.



**Japan Freight Railway**  
Hybrid shunting engine which commenced operations in 2012.



**Twilight Express Mizukaze**  
Japan's luxury train is powered by a diesel / electric hybrid system.



**Yangshan Port, Shanghai**  
Automated transfer vehicles at the world's largest automated wharf.

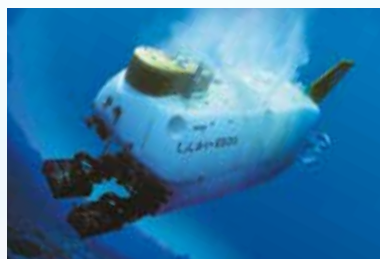

**Shinkai 6500 Submarine**  
A crewed research submersible capable of diving to depths of 6,500 metres.



**Kingsley II**  
Cutting edge conversion of a classic wooden ferry to a green hybrid-engine.

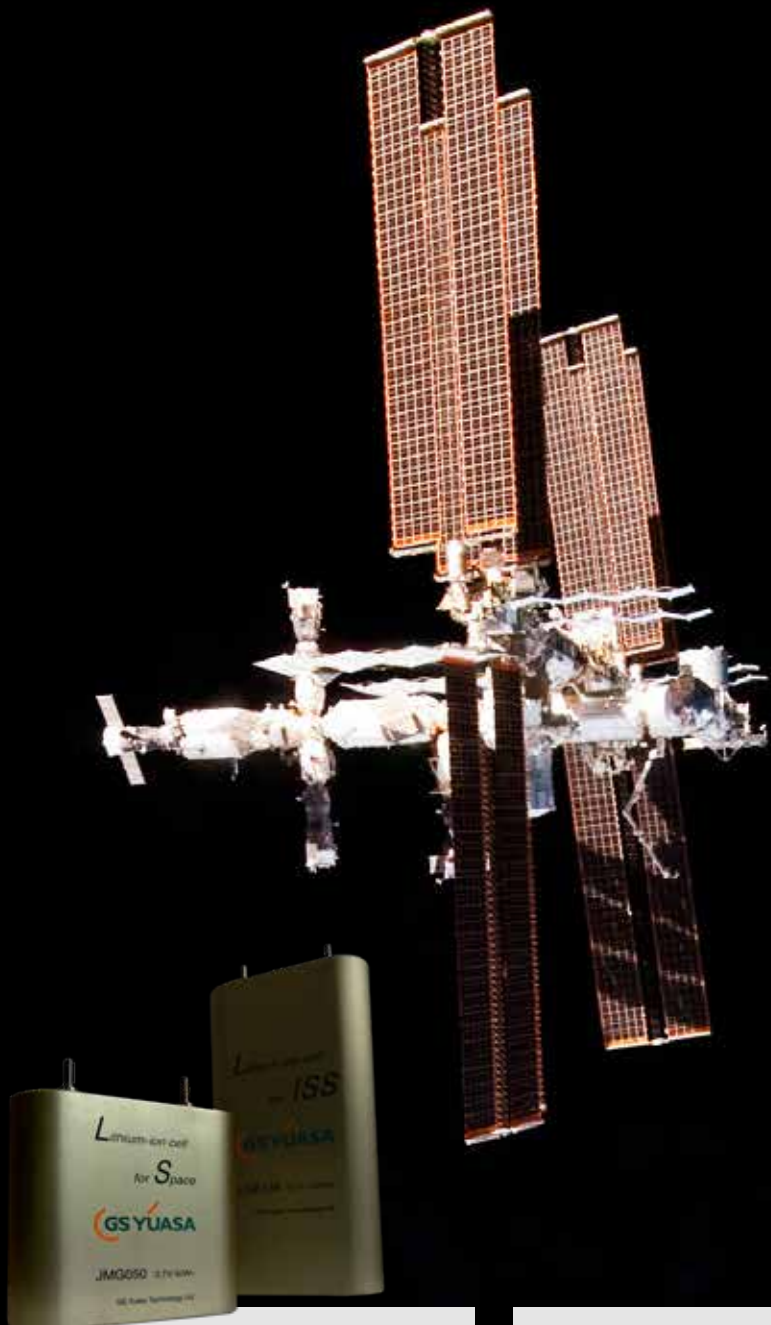

**Did you know? As well as the International Space Station, GS Yuasa supply over 200 satellites and even rockets with lithium-ion batteries.**

**We remain the only manufacturer to exceed four million Watt-hours of energy storage in orbit... more than all other manufacturers combined and we haven't had a single failure.**



**H-II Transfer Vehicle**  
Automated cargo spacecraft used to resupply the International Space Station.



**Mocean Blue X**  
Wave energy converters providing energy to ocean equipment and the grid.



**McLaren Formula 1**  
GS Yuasa powered McLaren for the 2005 - 2012 Formula 1 seasons.



**Mitsubishi i-MiEV**  
The first commercially available electric vehicle.



**Mitsubishi Outlander**  
One of the world's best selling plug-in hybrid vehicles.



**Axpo Butler S**  
A plug-and-play solution for the rapid provision of electricity to remote sites.



# Enabling a sustainable tomorrow through advanced energy storage solutions today

GS Yuasa lithium-ion technology has been tried and tested in hundreds of pioneering projects which contribute to the realisation of a low-carbon society.

With each project presenting its own unique requirements and challenges, the quality of GS Yuasa's products and wealth of technical expertise allows us to work with our customers to provide the optimum solution.



## Kushiro Town Toritoushi Wildland Solar Power Plant

Location: Japan  
Capacity: 6,750 kWh  
Power: 10,000kW

Smooths and stores energy output at Hokkaido's first mega-solar system installed with lithium-ion batteries.

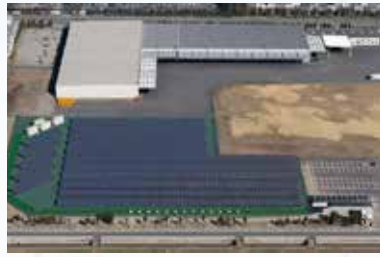

## Gunma Photovoltaic Power Plant

Location: Japan  
Capacity: 100 kWh  
Power: 300 kW

Accumulates renewable energy storing it for use during peak demand periods and during disasters.



## Grid independent multi-EV charging station

Location: Ireland  
Capacity: 100 kWh  
Power: 100 kW

Used to amplify available grid power for rapid EV charging during peak demand.



## Portsmouth International Port EV charging

Location: UK  
Capacity: 250 kWh  
Power: 100 kW

Dual chemistry energy storage system to integrate solar generation with port vehicle operations.



## Fukushima Railway Station

Location: Japan  
Capacity: 421 kWh  
Power: 200 kW

Stores energy to enable operation of from fully renewable local sources with additional anti-disaster units.



## ADEPT micro-grid ESS

Location: UK  
Capacity: 250 kWh  
Power: 100 kW

The world's first dual chemistry energy storage system used to store renewable energy.

## Innovation & technology

We invest heavily in research, development and product testing to ensure we continue to meet the needs of the market place and the wide range of applications our products are used to support.

## UK technical support

With a dedicated team of specialist engineers and technicians, our technical department provide support and advice to thousands of users each year, handling enquiries at all levels.

## Award-winning products & service

We pride ourselves on offering the best customer service, year-round availability and high quality products. Over recent years, we have been recognised with several prestigious awards.





### Cochrane Coal-fired Power Plant

Location: Chile  
Capacity: 6,750 kWh  
Power: 20,000 kW  
Provides excess capacity to stabilise the electrical grid system.



### GS Yuasa Kyoto Plant

Location: Japan  
Capacity: 506 kWh  
Power: 500 kW  
Stores energy from local renewable sources to use at peak periods of manufacture.



### TOBU Railway Corporation Ltd

Location: Japan  
Capacity: 110 kWh  
Power: 1800 kW  
Reduces power consumption by storing energy created through braking and then supplying it during acceleration.



### Energy Rental transportable UPS system

Location: Italy  
Capacity: 220 kWh  
Power: 320 kW  
Reduces diesel emissions associated with back up power operations.



### Hagigaoka Water Treatment Plant in Hokkaido

Location: Japan  
Capacity: 2,000 kWh  
Power: 3,000 kW  
Smooths and stores energy output from wind generation, supplying the plant and widely dispersed sites.



### Rassau Industrial Estate GS Yuasa plant

Location: UK  
Capacity: 600 kWh  
Power: 200 kW  
Stores energy from local renewable sources to use at peak periods of manufacture.



### Tokyo Tama Intercity Monorail

Location: Japan  
Capacity: 75 kWh / 03 kWh  
Power: 2,000 kW  
Captures regenerative braking energy to improve efficiency of the rail network.



### Chugoku Electric Power Corporation Inc

Location: Japan  
Capacity: 1,350 kWh  
Power: 2,000 kW  
Smooths and stores energy output from renewable energy on the isolated Oki Islands.



### Sumitono gantry cranes

Location: Japan  
Capacity: 14 kWh per crane  
Power: 100 kW  
Stores braking energy from crane operation for greater efficiency and emissions reduction.

## Quality guaranteed

Our customers can be confident that we have the tools in place to ensure customer satisfaction in products, supply and service.



ISO 9001  
Quality Management

ISO 14001  
Environmental Management

ISO 45001  
Occupational Health and Safety Management

TS 16949  
Automotive Quality Management

# Why GS Yuasa lithium-ion



## Long cyclic life at high power

GS Yuasa modules have been specifically designed to provide exceptional levels of cyclic performance, even during continuous high power operation. Unlike most lithium-ion options available, they do not compromise cyclic performance to deliver high power.

When compared to other lithium-ion options, GS Yuasa batteries provide:

- / Over 11,000 cycles at 100% depth of discharge for a prolonged service life.
- / Higher power in a compact footprint so system power requirements can be met in a considerably smaller space.



## Superior high charge and discharge performance

Manufactured for class-leading performance in applications where high charge and discharge rates are required. This is particularly important for energy capture applications such as wave power and kinetic energy capture.



## The right chemistry for the right application

With over 30 years experience, we offer a comprehensive range of products and various lithium-ion chemistries to provide the optimum solution for every application.



## Integrated solutions

To ensure ultimate reliability and safety, we design and manufacture GS Yuasa lithium-ion modules as a complete solution. This includes cells, modules, critical control components and advanced management software.



## Stainless steel cell container

The number one cause of short circuits in lithium-ion cells results from using nickel plated containers. GS Yuasa cells use stainless steel to eliminate this risk while providing exceptional corrosion resistance.



## No requirement for off-line balancing

Thanks to their lithium manganese chemistry, GS Yuasa LIM modules can be operated continuously in partial states of charge. They do not need to be taken out of service to allow cell balancing activities to take place.



## Environmentally responsible

Unlike most solutions on the market, GS Yuasa modules are constructed in a way that aids recycling.

They use lithium manganese chemistry which is widely available from responsible and recycled sources.

Lithium-ion technology is crucial to enabling a greener future through renewable power generation and storage.





## When compared to VRLA

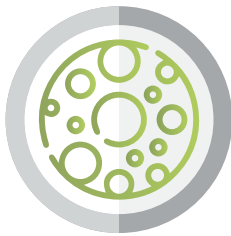

### Three times higher energy density

Provides more power from a smaller footprint and weight resulting in less floor loading.

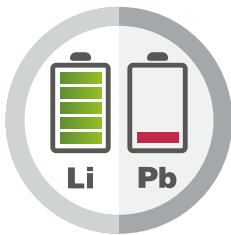

### More than double the service life

Providing a better return on investment and lower total cost of ownership.



### Up to 10 times more discharge cycles

Making them the preferred choice for continuously cycling applications.



### Greater depth of discharge

Dischargeable to 0% meaning you can use 100% of their capacity.



### Faster charging times

Typically a quarter of the time of traditional technologies.



# Engineered for unparalleled reliability

GS Yuasa lithium-ion cells are designed and manufactured in Japan using the highest quality components and processes.

- 1 Robust stainless steel prismatic case protects against impact while allowing for dissipation of heat during high-rate charging or discharging.
- 2 Flexible wound element, constructed with minimal edges ensures protection against short circuits to provide ultimate reliability.
- 3 Internal positive and negative connections are sited at opposite ends of the wound element to provide uniform current distribution for extended service life at high rates.
- 4 Robust high performance separator to provide protection against short circuits, preventing temperature increase and the damage this can cause.
- 5 Integrated pressure release plate is a safety feature designed to vent in the ultra rare event of gas building up within the cell.

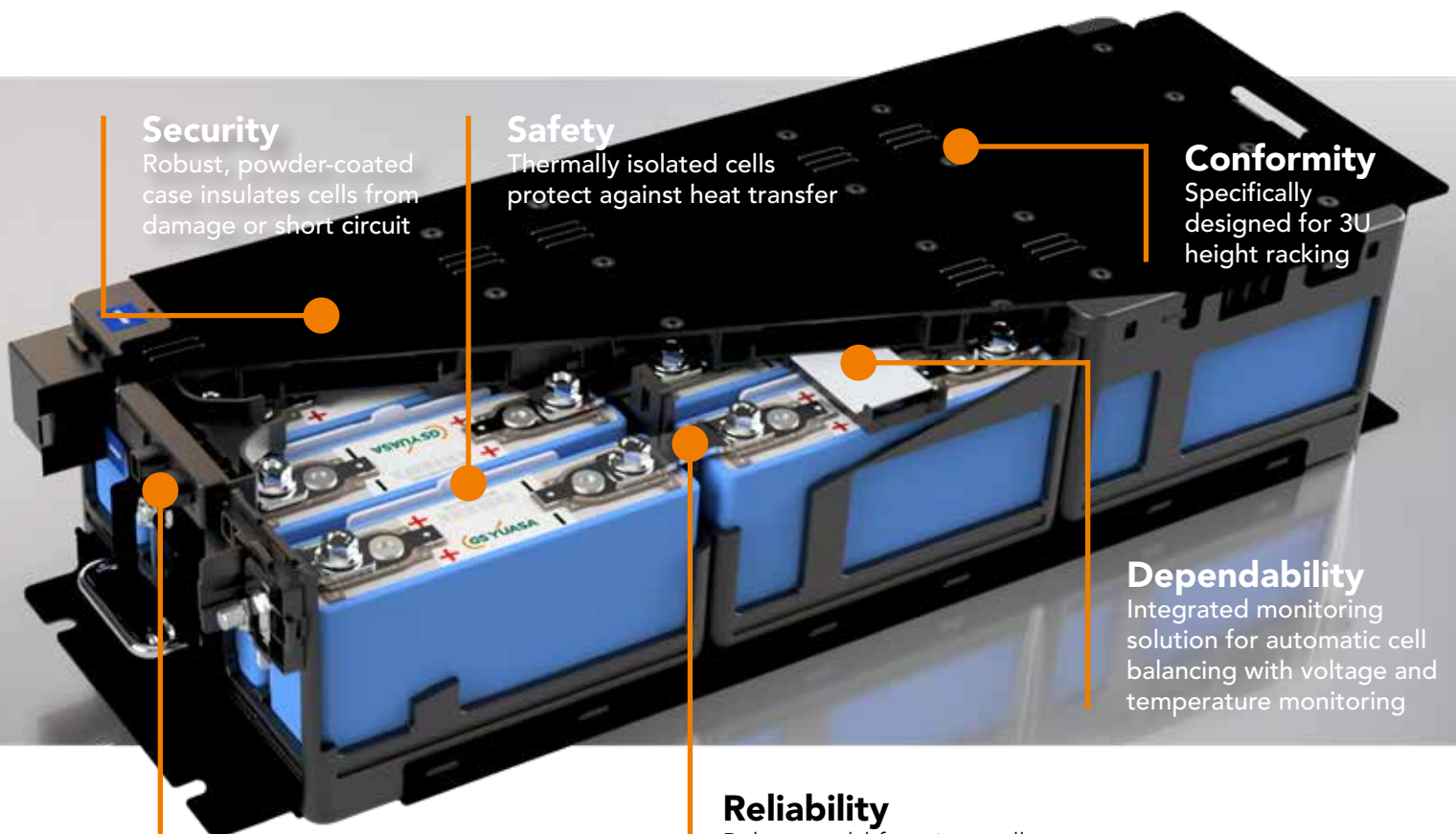
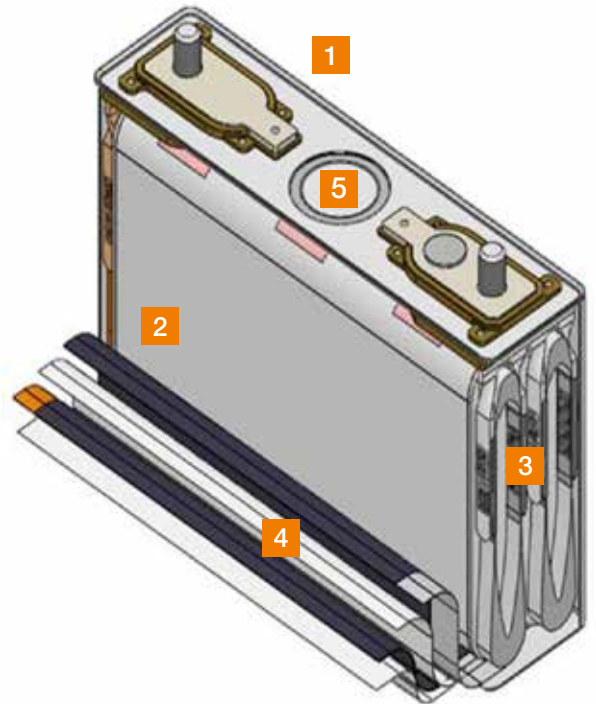

## Security

Robust, powder-coated case insulates cells from damage or short circuit

## Safety

Thermally isolated cells protect against heat transfer

## Conformity

Specifically designed for 3U height racking

## Dependability

Integrated monitoring solution for automatic cell balancing with voltage and temperature monitoring

## Reliability

Robust, weld-free, intercell connectors provide ultimate reliability and aid recycling

## Accessibility

Front terminal design with accessible, opto-isolated, communications port for ease of connection



## LIM30HL range



LIM30HL modules have exceptionally high power capabilities.

Ideal for applications in which two seconds to five minutes of discharge is required.

- Provides a cost effective alternative to flywheels or supercapacitors.
- Ideal for moving applications, such as material handling equipment, cranes and trains due to their ability to accept bursts of regenerative energy.
- Lithium manganese chemistry provides up to 50,000 cycles in partial state of charge conditions.
- Integrated battery management system to ensure cells are continuously balanced.

	LIM30HL-8*1	LIM30HL-12*1
Number of cells	8	12
Nominal capacity	31.5 Ah	
Nominal Voltage	28.8V	43.2V
Max. charging rate	600 A (24C) up to 14 seconds 314 A (12.6C) up to 180 seconds	
Max. discharging rate	600 A (24C) up to 14 seconds 271 A (10.8C) up to 300 seconds	
Ambient temperature	Charging -10 to +45°C Discharging -20 to +45°C	
Weight	17.5kg	27kg
Dimensions (L x W x H)	440 x 219 x 128 mm	617 x 219 x 128 mm

Suitable for:



High power applications



Diesel hybrid crane



Diesel hybrid trains



Short-duration UPS systems



Fuel cell hybrid transport vehicles

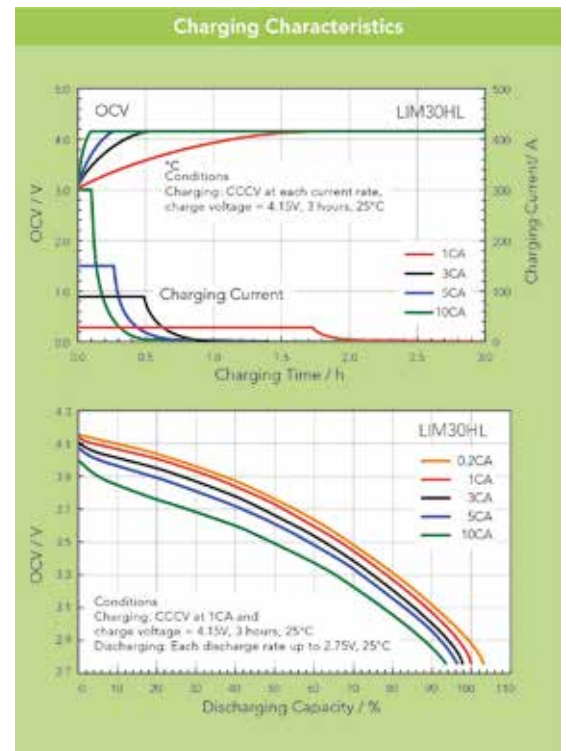

LIM30-12



LIM30-8



## Energy storage

### LIM50EL range



The LIM50EL is our premium energy storage module providing superior cyclic and standby life duration.

Ideal for applications in which two minutes to ten hours of discharge is required.

- Lithium manganese chemistry provides high energy density giving more power from a compact solution.
- Suitable for high voltage applications. Modules can be connected in series to meet the required system voltage.
- Can be used in parallel to create a high capacity energy storage solution.
- Charge acceptance capability extends to sub-zero temperatures.

	LIM50EL-7	LIM50EL-8	LIM50EL-12
Number of cells	7	8	12
Nominal capacity	50 Ah		
Nominal Voltage	26.6V	30.4V	45.6V
Max. charging rate	125 A (2.5C)		
Max. discharging rate	300 A (6C) up to 60 seconds 200 A (4C)		
Ambient temperature	-20 to +45°C		
Weight	15kg	18kg	27kg
Dimensions (L x W x H)	412 x 180 x 135 mm	440 x 219 x 128 mm	617 x 219 x 128 mm



LIM50-7



LIM50-8



LIM50-12

Suitable for:



Renewable energy and microgrids



Electric vehicle charging systems



Diesel generator hybrid systems



UPS systems



Transportable energy storage



Marine vessel propulsion



Material handling and automated guided vehicles

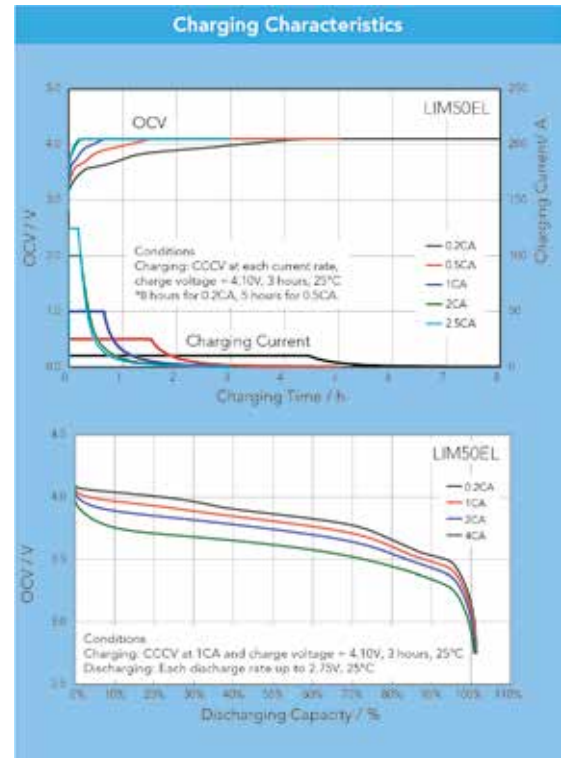







# LIM50EL 48 Volt module



Suitable for:

-  Telecoms
-  Off grid applications
-  Renewable energy storage
-  Remote locations

The 48 Volt module is a fully integrated energy storage package configured for use in 19" racking.

Ideal for back up and off grid applications in which two minutes to ten hours of discharge is required.

- Lithium manganese chemistry provides high energy density giving more power from a compact solution.
- GS Yuasa LiBM system built in for easy installation.
- Can be used in parallel to create a high capacity energy storage solution.
- Charge acceptance capability extends to sub-zero temperatures.

	LIM50EL-13
Number of cells	13
Nominal capacity	50 Ah
Nominal Voltage	49.4V
Max. charging rate	50 A (1C)
Max. discharging rate	50 A (1C)
Ambient temperature	-20 to +50°C
Weight	32.5kg
Dimensions (L x W x H)	480 x 437 x 130 mm

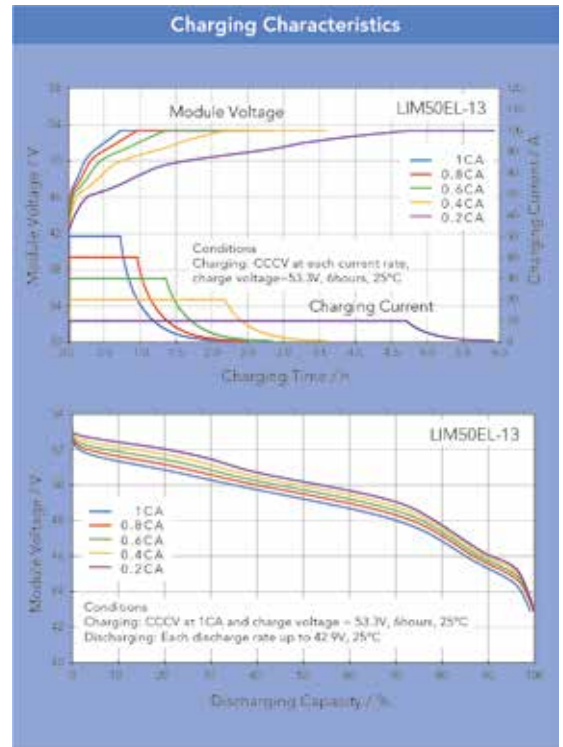

LIM50-13

# Fully scalable solutions for ESS applications



GS Yuasa LIM modules are a fully configurable solution which can be used to create powerful Energy Storage Systems (ESS) for all applications and environments and to meet any power requirement.

Our modules are easily scalable by design which means systems can range from a single module up to a field of large ESS containers full of thousands of modules.

Common configurations include ESS cabinet style units which can easily be integrated into commercial and industrial spaces to provide a flexible and dependable energy supply.

Cabinets can also be fully weatherproof allowing for outdoor installation in a completely flexible footprint.



Containerised ESS systems are housed within a 20 or 40ft unit which can be designed and built for the intended application's operational requirements. They are weatherproof and can be incorporated onto any site with no need for any internal space.

ESS containers can be used in multiples and also combined with smaller cabinet style units. The optimum solution will depend on your power requirements, application, the space available and it's location.

GS Yuasa engineers will fully assist with the specification development and selection of the premium solution for your project.





# Battery management system

Lithium-ion batteries operate as a system and not a stand alone unit. GS Yuasa manufacture and supply all of the key elements required for this battery management system architecture.

Every module is equipped with a battery monitoring PCB which measures cell voltage and module temperature, protecting the battery in case of overcharge, overdischarge or excessive heating.

## PCB LIBM II features

- Balancing function balances the voltage of connected modules.
- State of charge (SOC) calculation automatically calculates SOC which can be monitored in real time.
- Multiple banks batch monitoring using multiple LIBMII allows monitoring of systems with multiple modules.
- High voltage system specification up to 1500 Volts DC.

