

# XP SERIES-ULTRA HIGH RATE

## XP12-400 (12V400W)

# CONVEREX BATTERY

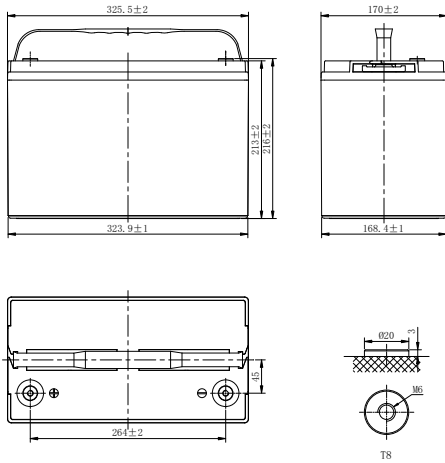

## CHARACTERISTICS

Item	Specifications	
Rated Voltage	12V	
Nominal Rate (25°C)	$W_{15}, 1.67V/cell$	422W/cell
Nominal Capacity (25°C)	$C_{20}, 1.60V/cell$	110Ah
Dimension	Length	325.5mm (12.8inches)
	Width	170mm (6.69inches)
	Container Height	213mm (8.39inches)
	Total Height	216mm (8.50inches)
Approx Weight	31.6kg (69.7lbs)	
Terminal	T8(M6)	
Container Material	ABS (UL94 HB or V-0 optional)	
Short-circuit current	2304A	
Internal Resistance (25°C)	Approx 3.6 mΩ (Fully charged)	
Operating Temp. Range	Discharge	-15~50°C (5~122°F)
	Charge	-20~40°C (-4~104°F)
	Storage	-15~40°C (5~104°F)
Nominal Operating Temp. Range	25±3°C (77±5°F)	
Max.Charging Current (25°C)	0.25C	
Charge voltage (25°C)	Standby Use	Equalization Use
	2.25-2.30V/cell	2.30-2.40V/cell
Temp. Coefficient	-3mV/cell/°C	-4mV/cell/°C
	40°C (104°F)	106%
Effect of temp. to Capacity	25°C (77°F)	100%
	0°C (32°F)	86%
	Self Discharge	≤3% per month at 25°C (77°F)

## DISCHARGE TABLE

Constant Current Discharge (Amperes) at 25°C (77°F)															
F.V/Time	5min	10min	15min	20min	30min	45min	1h	2h	3h	4h	5h	6h	8h	10h	20h
1.85V/cell	244.7	193.8	168.2	139.3	107.2	78.0	58.4	33.8	25.0	20.0	16.8	14.6	11.4	9.37	4.94
1.80V/cell	290.9	220.9	186.4	152.0	114.8	82.3	61.5	35.2	26.0	20.8	17.5	15.0	11.7	9.60	5.08
1.75V/cell	327.2	243.0	200.9	161.7	121.8	86.1	65.1	36.5	26.8	21.4	17.9	15.4	12.0	9.81	5.20
1.70V/cell	357.7	258.7	211.8	169.6	126.7	89.8	67.8	37.9	27.6	21.9	18.2	15.7	12.2	10.0	5.26
1.67V/cell	391.3	274.3	222.6	171.8	129.4	91.1	69.5	39.0	28.4	22.5	18.7	16.1	12.5	10.1	5.30
1.60V/cell	410.1	285.9	229.4	181.8	133.8	94.1	72.4	39.7	28.9	22.8	18.9	16.3	12.6	10.3	5.33
Constant Power Discharge (Watts/cell) at 25°C (77°F)															
F.V/Time	5min	10min	15min	20min	30min	45min	1h	2h	3h	4h	5h	6h	8h	10h	20h
1.85V/cell	476.2	379.1	330.9	275.3	213.1	155.8	117.0	68.1	50.4	40.6	34.2	29.7	23.4	19.3	10.2
1.80V/cell	559.9	427.7	363.0	297.7	226.2	163.0	122.4	70.4	52.2	41.9	35.3	30.5	23.9	19.7	10.4
1.75V/cell	623.5	466.1	387.8	313.9	237.8	169.2	128.6	72.5	53.4	42.9	35.9	31.1	24.4	20.0	10.6
1.70V/cell	673.9	490.7	404.0	325.8	244.9	174.9	133.0	74.7	54.8	43.6	36.4	31.4	24.6	20.2	10.7
1.67V/cell	731.1	516.5	422.0	328.0	248.8	176.3	135.4	76.5	55.9	44.5	37.2	32.0	25.0	20.4	10.7
1.60V/cell	757.7	532.5	430.4	343.7	254.8	180.4	139.9	77.1	56.5	44.8	37.3	32.2	25.0	20.4	10.7

# XP SERIES-ULTRA HIGH RATE XP12-400 (12V400W)

# CONVEREX BATTERY

## APPLICATIONS

- UPS
- Hospitals and Testing Laboratories
- Emergency Power Supply
- Electric starting
- Telecommunications
- Data Centers

## GENERAL FEATURES

- 12 years design life (25°C)
- Excellent high current performance - optimised for short discharge time
- Advanced AGM technology for superior high-rate power
- Long Life Alloy - minimizing grid growth, reducing gassing and extending battery life
- Epoxy-sealed posts eliminate leaks
- Optimal energy density - saves floor space

## STANDARDS

- Compliance with IEC 60896 standards
- Classified as "Long Life" according to Eurobat
- CE,UL Approved
- Manufactured in IATF 16949, ISO 45001,ISO 9001 and ISO 14001 certified production facilities

### Discharge Characteristics

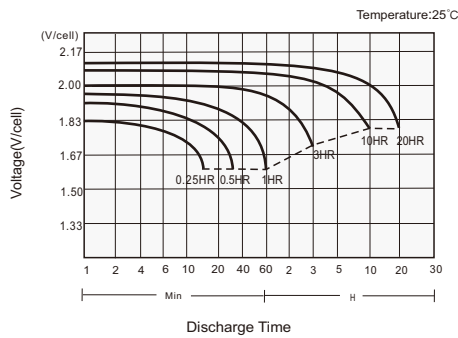

### Charging Characteristics

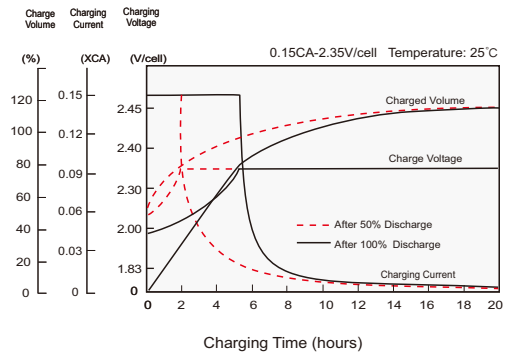

### Effects of Temperature on Capacity

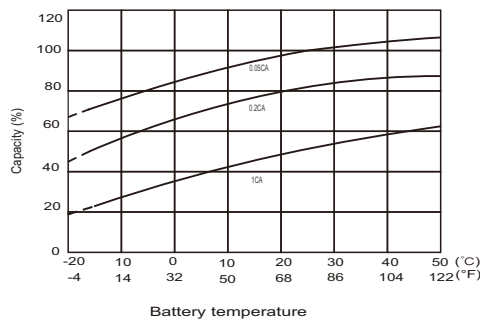

### Self Discharge Characteristics

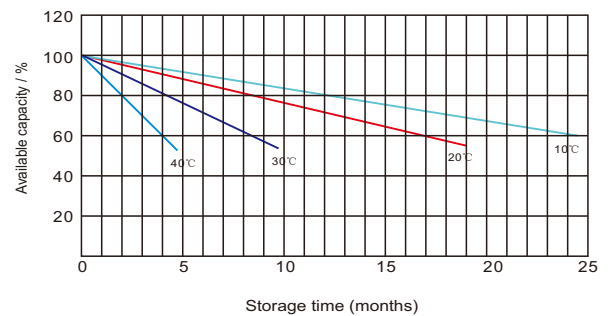

## UPS ELEKTRON K T C. A .

Ferhatpa a Mah 43. Sk No: 52-54 Ata ehir/ stanbul 34888 Türkiye  
 Tel: +90 216 466 95 50      Whatsapp: +90 532 318 02 06  
 www.upselektronik.com      www.riello-ups.com.tr